



TECHNICAL PAPER

Title: Lowering LNG Unit Costs Through Large and Efficient LNG Liquefaction Trains – What is the Optimal Train Size?

Authors: Philip Hunter, Amos Avidan, John M. Duty – Bechtel Corporation
Non-Bechtel authors: Anthony Eaton, Rick Hernandez, Allyn Risley

Date: April 25-29, 2004

Publication/Venue: LNG 14

LOWERING LNG UNIT COSTS THROUGH LARGE AND EFFICIENT LNG LIQUEFACTION
TRAINS – WHAT IS THE OPTIMAL TRAIN SIZE?

Anthony Eaton, Rick Hernandez, and Allyn Risley
ConocoPhillips Company
600 N. Dairy Ashford
Houston, TX 77077

Phil Hunter, Amos Avidan, and John Duty
Bechtel Corporation
3000 Post Oak Blvd.
Houston, TX 77056

Keywords: LNG, large trains, costs

Prepared for presentation at the 2004 Spring Meeting, New Orleans, LA., April 25-29

Unpublished

AIChE shall not be responsible for statements or opinions contained in papers or printed in its
publications.

Abstract

The international LNG trade is undergoing an unprecedented period of growth, and LNG plant owners keep searching for ways to lower costs by benefiting from economies of scale. Bechtel has recently designed and is constructing the world's largest LNG train, with a nominal capacity of over 5 million tonnes per annum (mtpa), utilizing the Phillips Optimized Cascade LNG Process. Bechtel and ConocoPhillips have also engaged in a detailed study of larger LNG trains through our LNG Product Development Center, and conclude that LNG trains as large as 8 mtpa are feasible, and could be cost-effective.

Although such “mega” LNG trains are feasible they may not be suitable for everyone. We see LNG plant designs in the coming decade falling broadly into three groups, with nominal capacities around 4 mtpa, 5 mtpa, and 8 mtpa. These different train designs are likely to co-exist in the coming years, as different owners find it advantageous to choose one vs. another. The basic design of 4 mtpa trains (until recently considered very large trains) will continue to suit new grassroots projects with limited gas supply or committed gas sales, or in cases where copying an existing train design is the most cost-effective option. Approximate 5 mtpa trains could be suited for expansion or grass roots projects that require lower LNG unit costs, and have the available gas supply and sales. An 8 mtpa “mega” train would be most suitable for an expansion train at a very large existing LNG complex targeting a large, distant market, with virtually unlimited gas supply.

One question facing designers of large-capacity trains is: “How does a single 8 mtpa train compare in cost and operational flexibility vs. two 4-mtpa trains?” Our study to answer this question was based on the Phillips Optimized Cascade LNG Process with three refrigerants (propane, ethylene, and open-loop methane). The study explored innovative configurations based on Frame 7 and Frame 9 gas turbines, liquid and gas expanders, utilization of heat recovery systems and electric drives. Plant capacities studied ranged from 3.3 mtpa to 8 mtpa.

We have concluded that large trains can be feasible and cost-effective. The compressors utilized in our studies represent some of the world's largest but they meet acceptable guidelines for major design parameters. Other design parameters investigated included: feasible line and valve sizes, size of heat exchangers, cold boxes and other key equipment.

One major concern with “mega” LNG trains is significant reduction in LNG production when one of the refrigerant compressor trains goes out of service. This problem can be mitigated with the Phillips Optimized Cascade LNG Process “two-train-in-one” reliability concept which allows the LNG train to operate at up to 75% capacity even when one compressor string trips. LNG trains utilizing this design have demonstrated on-stream availability greater than 95%, the highest in the LNG Industry. The outstanding safety, reliability, and high operating factors of the LNG industry keep building up confidence in larger trains, and the trend to design larger trains will keep accelerating.

Introduction

The international LNG trade continues expanding rapidly. The trend toward even larger capacity plants is a drive in the industry. LNG plants in the future will have nominal capacities up to 8.0 MTPA. This rising capacity requires major focus on train configuration, compressor selection, and economies of scale. This can be seen in Figure 1.

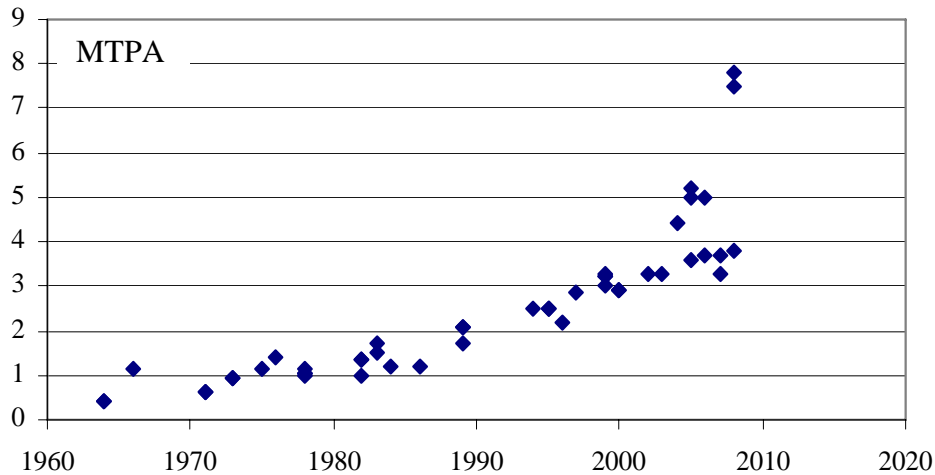

Figure 1. Trend in LNG train size (MTPA) in the future years

As the LNG trade increases and becomes more than a small niche-market, owners continue to look for ways to lower costs by benefiting from economies of scale. The effort has concentrated, as plant capacity grows, on building larger single LNG train plants.

We have concluded that large trains are feasible and cost-effective. To achieve the desired results, it requires innovation, “out of the box” thinking, technological rigor, and a “can-do” attitude. For example, the compressors utilized in our studies represent some of the world's largest, yet they meet all design parameter guidelines.

Our study focused on the scale-up of the Phillips Optimized Cascade LNG Process (POCLP) to achieve the higher plant capacity at approximately 8.0 MTPA. Phillips Petroleum Company developed the original Optimized Cascade LNG process in the 1960's. The objective was to develop a liquefaction technology that permitted easy start-up and smooth operation for a wide range of feed gas conditions.

This process was first used in 1969 at Phillips Petroleum Company's Kenai, Alaska LNG facility. The facility was constructed by Bechtel and was the first to ship LNG to Japan. It is the first LNG project in the world to achieve 34 years of uninterrupted supply to its Japanese customers. Figure 2 provides an overall schematic of a typical POCLP.

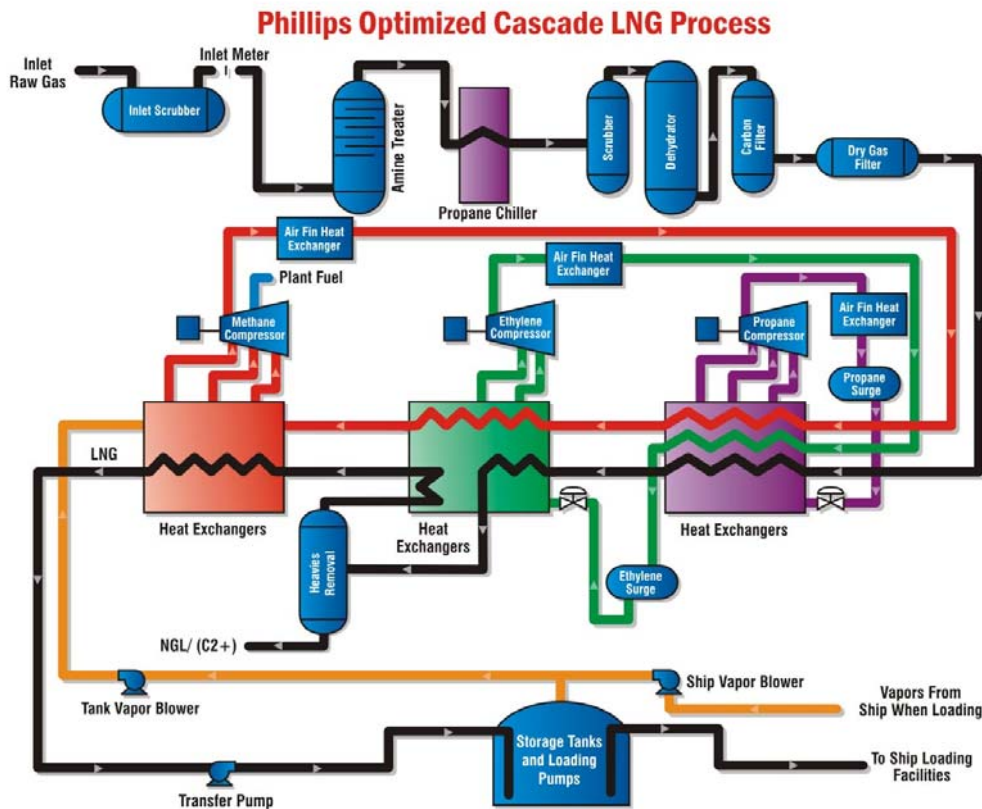

Figure 2. Phillips Optimized Cascade LNG Process – Train Size 1.0 to 8.0 MTPA

The POCLP is able to provide designs with high thermal efficiency and achieve a design that is optimized for project economics. The process utilized proven technology and equipment and has a wide range of operations flexibility. The operational flexibility can be seen in Table 1. Turndown rates to 10% are achievable for long-term operation. Due to the pure component systems, the plant provides an ease of startup and operation. The plants boast a low utility requirement and reduced flaring requirements since the refrigerants are not flared on typical upset conditions. This leads to reduced requirements for maintenance and operations staffing.

Operational Flexibility – In Percent of PFD Design Production		
	Low	High
Overall	10	105
Full Rate	90	105
One Turbine/Compressor Down	60	80
Half Rate	30	60
Idle	10	30

Table 1. Operations Flexibility in the Phillips Optimized Cascade LNG Process

The POCLP also provides for a “2-Trains-in-1” reliability option to offer high availability. Recent reliability and availability analysis shows overall plant availability of greater than ninety five percent. This has been demonstrated in operation at Kenai for over 34 years, and in Atlantic LNG for over 5 years. Figure 3 provides an overall layout of the “2-Train-in-1” concept.

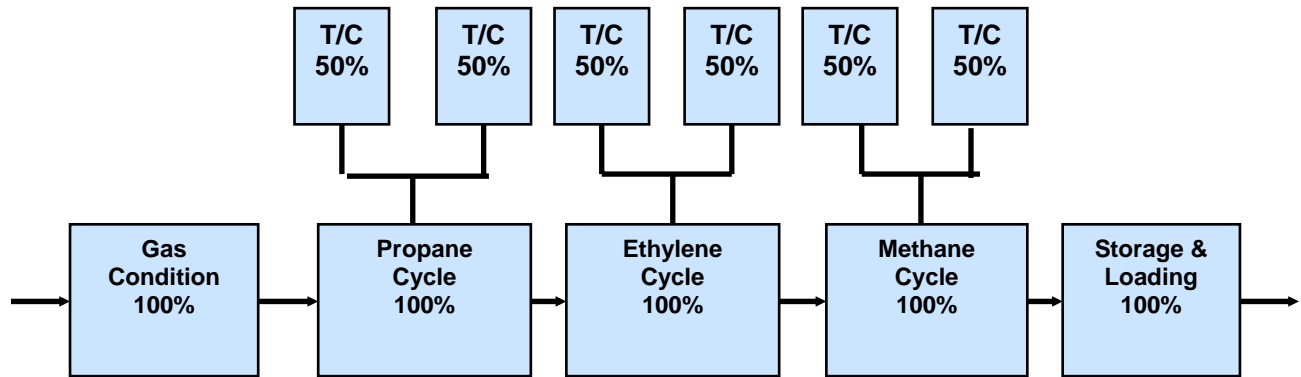

Figure 3. “Two-Trains-in-One” Operational Availability Concept in the POCLP

Study Basis

Table 2 provides an outlook at the various configurations that have been investigated for the Phillips Optimized Cascade LNG Process.

DESCRIPTION	UNITS	FRAME 5	FRAME 7EA	FRAME 7 C2/C3	FRAME 9E C2/C3	FRAME 5 2 TRAINS
LNG Production	MTPA	3. ++	5. ++	5. ++	7. ++	6++
Comparative Total Direct Cost per TPA		100.0	77.7	84.2	72.0	80.4

Table 2. Driver/Compressor Comparison Summary for the Phillips Optimized Cascade LNG Process

The innovative configuration shown in Figure 4 is designed to use large, single shaft GE Frame gas turbines in order to achieve a plant nominal capacity of 8.0 MTPA using the Phillips Optimized Cascade LNG Process. The plant configuration and layout of turbo-compressors are driven by the requirements to maximize plant reliability, maintain plant flexibility, meet environmental targets, minimize capital expenditure, and reduce operating expenditures.

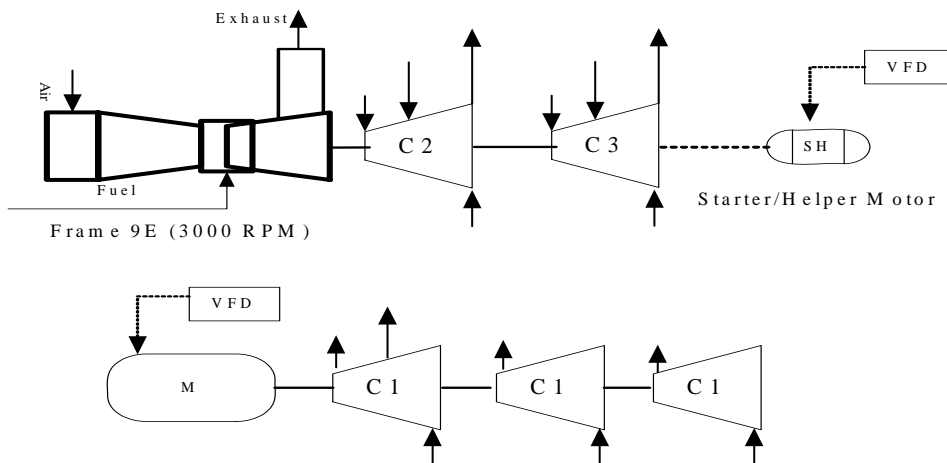

Figure 4. Large Train Concept in the Phillips Optimized Cascade LNG Process

The “two-trains-in-one” configuration achieves higher reliability and maintains flexibility advantages since the train can operate at capacities up to 75% with one of the two lines down. The 8.0 MTPA line-

up illustrated produces approx. 110 MW per gas turbine string and 60 MW per electric motor string. Once the compressor string is on-line, the starting motor is utilized as a helper to achieve the desired LNG production. Propane and ethylene are on the same shaft. Both strings are redundant in a 2x 50% configuration.

As part of the study, the Cold Boxes have been redesigned and are available for the 8.0 MTPA facilities. Overall requirements for weight and dimensions to allow shallow draft delivery have been maintained. Equipment, in terms of vessels, pipe, valves, and fittings, is available for the train size considered.

To further improve overall facility capacity, capability, reliability, and efficiency, engineered options are available as follows:

- Partial/Full Waste Heat Recovery
- Liquid Expander / Generator
- Expander / Compressor
- Inlet Air Chilling for GT drivers
- Electric motor drives

The technology for enhanced removal of NGL and LPG in the Phillips Optimized Cascade LNG Process has been improved for the most recent trains designed. Based upon technology improvements and observances of the operation of the previous designed trains, a more efficient process was devised for enhanced NGL/LPG recovery. The process was improved to add reflux and heat exchange systems to the NGL and LPG removal system. The alterations provide improved operability and flexibility of the product specifications. It also provides the capability of deep LPG recovery when desired. The design can accommodate for increased ethane recovery from the natural gas feed stream. This allows the designed facility to alter operations to maximize the facility product economic drivers. The process can easily shift from a NGL recovery to LPG recovery to ethane recovery configuration depending upon the economic drivers.

Design Basis

- 2 Frame 9's, 2 60 MW electric motors, 2-in-1, NP compressors study, Cold box design and shallow draft delivery, full NGL recovery and integration, other critical equipment such as valves

- Option to the design basis: WHR, liquid expanders, inlet air chilling, all electric drive
- Utilizing 2 – 160,000 m3 tanks and 3 – 200,000 dedicated ships

Table 3 provides typical adjustments to base for the options in the Phillips Optimized Cascade LNG Process.

Option	Availability	Production Efficiency	Production	Thermal Efficiency
Base Case	---	---	---	---
Inlet Air Chilling	+ 0.0	+2.81	+6.01	-0.60
Waste Heat Recovery	+0.75	+0.17	-0.98	+1.19
Liquid Expander	+0.0	+1.49	+4.04	+0.45
All Electric Motors	+2.57	+1.07	+0.0	-0.871

Table 3. Options Summary for the Phillips Optimized Cascade LNG Process

Assumptions for the above table are:

- 1) Inlet Air Chilling from 79F to 60F and will be further supported by future studies
- 2) Waste Heat Recovery has 12 in of outlet duct losses resulting on loss of available power and will be further supported by future studies
- 3) Assumes 75% isentropic efficiency for the liquid expander and is supported by current studies.

The electric motor case is designed to equivalent capacity and supported by current studies.

Schedule

- Pre-FEED studies complete, ready to start FEED/EPC immediately

- Milestone schedule

- Process targets – 28 to 32 months EPC
- Tanks target - 32- 34 months EPC

Startup

Start-up of the facility at larger sizes is essentially the same as the smaller trains. The single component refrigerants provide the ease of establishing and managing the refrigeration systems. The basic exchanger equipment utilized allows for improved and faster cool down rates for equipment as well as ease of control of cool down of equipment. The “two-train-in-one” approach in refrigeration units gives better flexibility during machine trips/shut downs, which corresponds to reduced LNG production versus total loss of production. The flaring requirements are minimal since there are no refrigerants flared during trips/shut downs. The design provides for a simple and easy to operate utility support systems. The control system has been simplified to facilitate easier start up or shut down. The process lends itself to quick recovery time after trips/shut downs and LNG production is back to full rates for a cold restart within 2-4 hours, warm restart within 4-8 hours. The factors lead to low staffing requirements for commissioning and start up of facility. Also, reduced numbers of cryogenic equipment and piping with no specialty items such as spiral wound heat exchangers.

Operability

The operability of the larger designs is expected to change with the use of differing plant turbine and compressor combinations. However, many of the aspects of a Phillips Optimized Cascade LNG Process plant are expected to stay the same. The plant turndown capability can range from 0-100% whilst maintaining good efficiencies. Single component refrigerants are easier to maintain versus other refrigerant types since there are no compositional adjustments to maintain efficiencies. There is no flaring of refrigerants and minimal flaring of process gases/liquids during trips/shut downs. There is a simplified control scheme for DCS and for equipment for ease of operation. The design allows for quick evacuation of compressor casings for quick restart when necessary. The process will maintain the same quick recovery time after trips/shut downs. Therefore, LNG production will be back to full rates for a cold restart within 2-4 hours, warm restart within 4-8 hours. The major maintenance programs can be executed while the plant is still on reduced production. And finally, there are low staffing requirements for plant operation and maintenance.

Conclusions

We envision LNG plant designs in the coming decade falling broadly into three groups, with nominal capacities around 4 mtpa, 5 mtpa, and 8 mtpa. These different train designs are likely to co-exist in the coming years, as different owners find it advantageous to choose one vs. another. The basic design of 4 mtpa trains (until recently considered very large trains) will continue to suit new projects with limited gas supply or committed gas sales, or in cases where copying an existing train design is the most cost-effective option. Approximate 5 mtpa trains could be suited for expansion or grass roots projects that need to lower LNG unit costs, and have the available gas supply and sales. An 8 mtpa “mega” train would be most suitable for an expansion train at a very large existing LNG complex targeting a large, distant market, with virtually unlimited gas supply.

We have concluded that large trains can be feasible and cost-effective. The compressors utilized in our studies represent some of the world's largest but they meet acceptable guidelines for major design parameters. Other design parameters investigated included feasible line and valve sizes, size of heat exchangers, cold boxes and other key equipment.

One major concern with “mega” LNG trains is significant reduction in LNG production when one of the refrigerant compressor trains goes out of service. This problem can be mitigated with the Phillips Optimized Cascade LNG Process “two-train-in-one” reliability concept which allows the LNG train to operate at up to 75% capacity even when one compressor string trips. LNG trains utilizing this design have demonstrated on-stream availability of greater than 95%, the highest in the LNG Industry. The outstanding safety, reliability, and high operating factors of the LNG industry keep building up confidence in larger trains, and the trend to design larger trains will keep accelerating.